



UPDATED
VERSION
MAR 2010

PRODUCT SPECIFICATIONS

WHEREVER THERMOSTATIC CONTROL - ROUGH & TRIM (WE-THERM-3/4)

3/4" THERMOSTATIC ROUGH VALVE

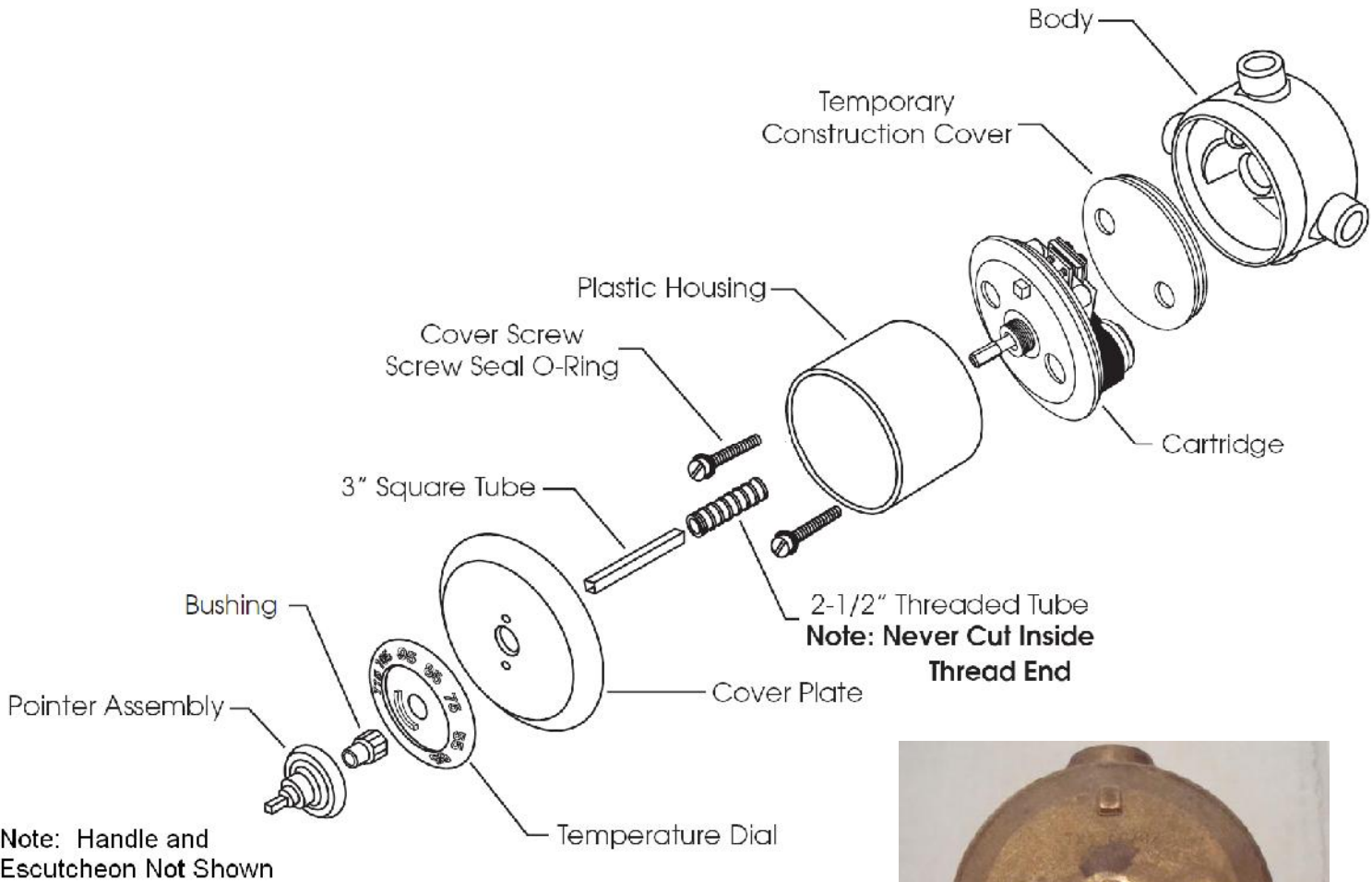

FACTS

3/4" Inlets, 3/4" Outlets



PRODUCT SPECIFICATIONS

WHEREVER THERMOSTATIC CONTROL - ROUGH & TRIM (WE-THERM-3/4)

THERMOSTATIC CONTROL TRIM

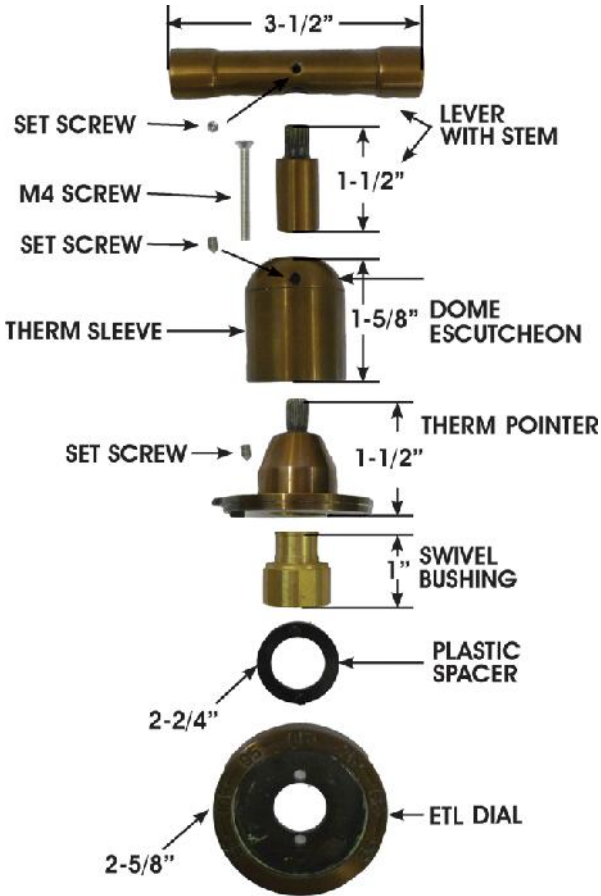

THERM PLATE

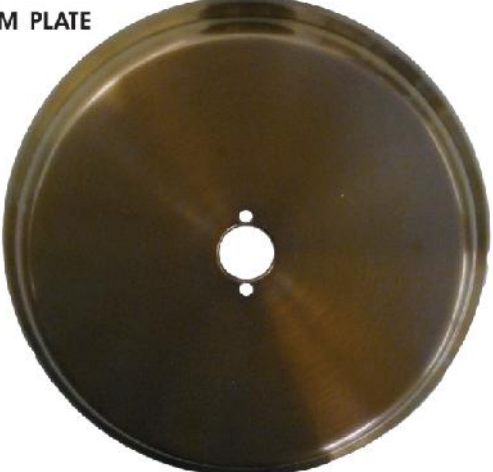

FACTS

3-1/2" Overall projection
7-3/8" Round trim plate

Available in 4 Standard Finishes:
(WherEver collection)

- Rustic Copper (RC)
- Rustic Nickel (RN)
- Pizzazz Nickel (PN)
- Oil Rubbed Bronze (ORB)