



UPDATED  
VERSION  
NOV 2009

## INSTALLATION INSTRUCTIONS

### CIXX WALL MOUNT – Applies to Lav & Roman Tub Tiller



#### ROUGH-IN

1. Determine desired vertical and horizontal placement for spout and valves in relation to your basin.
2. Cut three holes in finished wall for;
  - valve stems ( 1" diameter)
  - spout injector (1-1/4" diameter)
3. Assemble watertight piping to valves and to spout injector.  
NOTE: Valve stem and injector measurements from surface of finished wall must be provided as shown
  - Valves (1-11/16" from finished wall to tip of inner valve stem)
  - Spout injector ( 1-1/8" from finished wall to tip of injector)

#### TRIM INSTALLATION

4. Place a blanket or padding underneath the work area to protect surface.
5. Slide the valve stem extension onto the end of the valve stem and thread the escutcheon.
6. Before the stem exits the top of the escutcheon, insert the handle into the hole on the end.
7. Finish threading the escutcheon onto the valve stem, seating the handle.
8. If it feels like there is binding when the stem extension engages the handle, carefully back it off and try again. If installed improperly, the handle will wobble and the stem may break when used.
9. Lubricate spout injector O-ring and place spout over injector. Position outlet down and fasten with set screw.



UPDATED  
VERSION  
NOV 2009

# CIXX WALL MOUNT - LAV & ROMAN

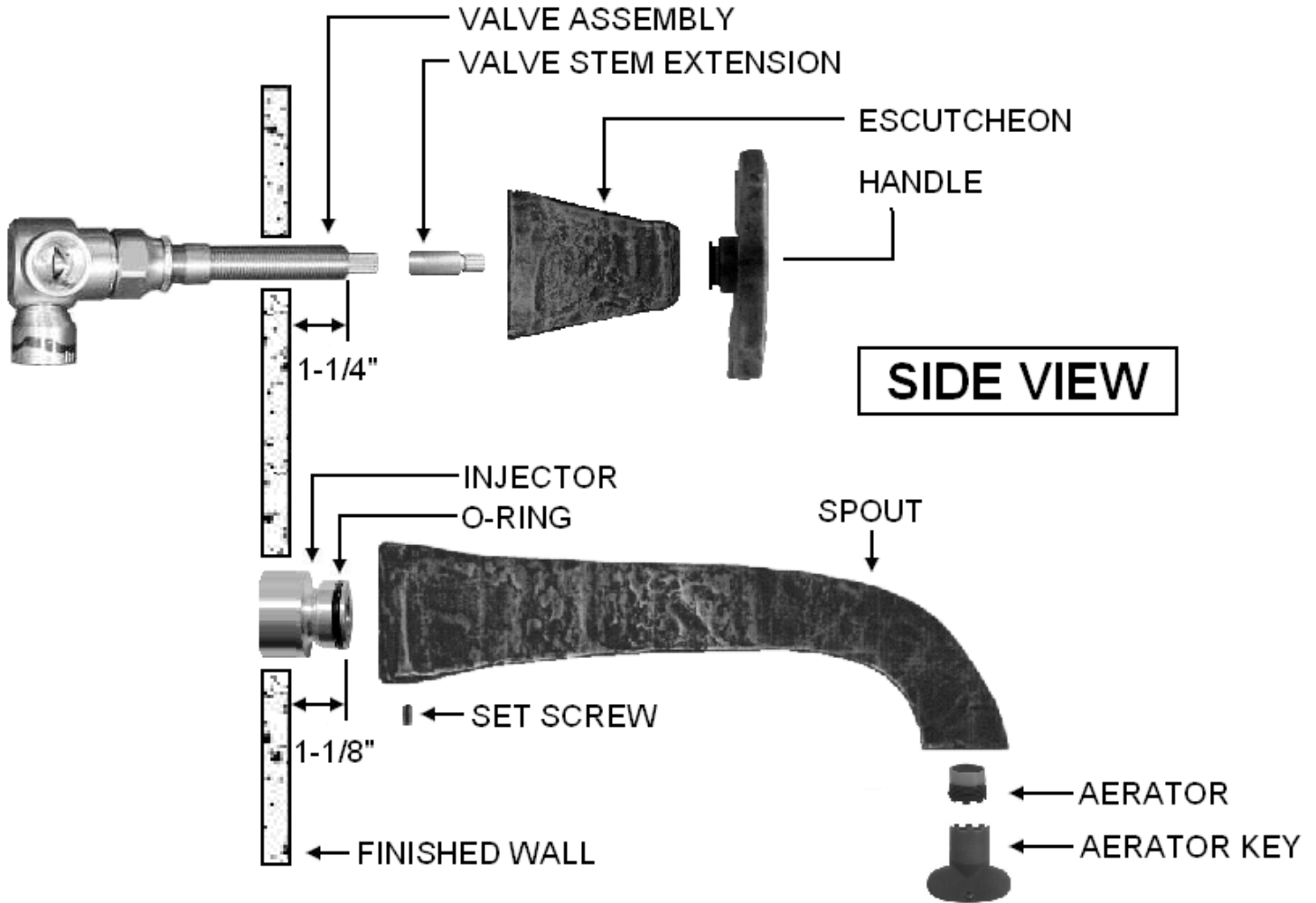



UPDATED  
VERSION  
NOV 2009

CIXX WALL MOUNT - LAV & ROMAN

