



UPDATED
VERSION
OCT 2009

PRODUCT INSTALLATION GUIDE

WATERBRIDGE REMOTE TUB DRAIN & OVERFLOW (WB RTDO) FOR USE WITH "VESSEL" TYPE TUBS

The Sonoma Forge WaterBridge Remote Tub Drain & Overflow Tower (WB RTDO) is designed for use with Sonoma Cast Stone's "DoubleWave" and "Ofuro" soaking tubs. It can be used however, with any "vessel" type tub (one that does not have an integral overflow as part of its design) with a maximum water height of 25-1/2" (3" below tub rim).



General Theory of Operation: The WB RTDO is basically a tube within a tube. The Control Knob at the top of the RTDO, controls whether water fills the tub or allows the water to drain. When the inner tube is placed in the "down" position (turn the knob until it slides down) the drain is "closed" allowing the tub to fill. As the water fills the tub, it also fills the outer tube of the RTDO. The tub will continue to fill until it reaches the overflow water level selected for the tub being used. Excess water entering the tub will then begin to "overflow" into the inner tube, and down the drain. To drain the tub, simply lift and turn the Control Knob until it rests in the up (or open) position.



**UPDATED
VERSION
OCT 2009**

Adjustment to the water height in the tub can be made by sliding the rubber sleeve on the inner tube, either up or down as needed. There are one inch “hatch marks” on the inner tube measured from the top of the tube down. These are measured from the bottom of the floor flange which mounts on to the finished floor. Factory setting is in the lower position. More on this in a later section.

1) General Preparation

- a) Observe all applicable building and plumbing codes.
- b) For concrete slab floor - make block-outs as shown. A clean 4” diameter hole is required for Sonoma Forge’s Remote Tub Drain & Overflow floor flange assembly.
- c) For wood frame floor assembly - ensure structure can support weight of tub and water, while allowing clearance for drain connections.
- d) Inspect all parts for damage.
- e) Install bath on sturdy, level floor.
- f) Install the rough-in for Sonoma Cast Stone “DoubleWave” or “Ofuro” according to tub used and dimensions shown.
- g) Plan for access to final plumbing connections.
- h) Floor flange fastening screws or lag bolts (not included) should be stainless steel, bronze or hot-galvanized.
- i) Positioning the tub – place the tub on the spot desired. Use the Sonoma Forge Remote Tub Drain & Overflow along with the WaterBridge Floor Mount Roman Tub Filler (WB RTF FM) (if applicable) to determine final adjustments to the tub placement.

NOTE: The RTDO can be placed anywhere in the room. There is no need to position it adjacent to the tub itself.

NOTE: The WaterBridge Remote Tub Drain & Overflow is shipped assembled to assist in positioning final resting place of tub. Depending on your specific application, please refer below to either Item 2 (for Slab Floors) or Item 3 (for Wood Frame Floors).

2) Install the Tub - Slab Floor

- a) Position tub over floor opening.
- b) Raise tub on 8”-12” high wood blocks.
- c) Install drain outlet to tub.
- d) Lower tub into position.
- e) You are now ready to install the Floor Flange. See Item 4 below for disassembling the WB RTDO.
- f) Place the WB RTDO “Floor Flange” with attached bronze tee in the 4” diameter hole. Orient the horizontal tee inlet towards the tub outlet fitting. Mark & drill for screw anchors.
- g) Screw the Floor Flange to the slab using expansion screw anchors and 1/4 - 20 x 2 machine screws. It is also a good idea to use construction epoxy in the bolt holes.



UPDATED
VERSION
OCT 2009

- h) Ensure the floor is level, clean & dry. Set the Floor Flange in silicone adhesive sealant or epoxy.
- i) Make sure the Floor Flange is perfectly level in both directions. If necessary, shim level with temporary plastic shims and use construction epoxy for a solid bed.
- j) Protect the Drain Seat from damage & debris.
- k) Complete under floor connections through access opening. Leak test. Access opening may be patched and finished at this point.

3) Install the Tub - Wood Frame Floor Assembly

- a) Make any floor framing modifications needed for drain connections without compromising framing stiffness.
- b) The subfloor should be minimum 3/4" sound plywood.
- c) Lay out and bore a 3" diameter hole for tub outlet.
- d) Lay out and bore a 4" diameter hole for Floor Flange. The center must be at least 3-1/4" away from the outermost edge of the tub.
- e) As long as there is easy access to the drain area from under the floor, place the tub in position, then install the drain outlet.
- f) Or, position tub over floor opening, raise tub on 8"-12" high wood blocks, install drain outlet, then lower tub into position.
- g) You are now ready to install the Floor Flange. See Item 4 below for disassembling the WB RTDO.
- h) Place the Floor Flange with attached bronze tee in the 4" diameter hole. Orient the horizontal tee inlet towards the tub outlet fitting. Mark & drill for screws or lag bolts (not included). Screw the Floor Flange to the subfloor using the wood screws or lag bolts.
- i) Ensure the floor is level, clean & dry. Set the Floor Flange in silicone adhesive sealant or epoxy.
- j) Make sure the flange is perfectly level in both directions. If necessary, shim level with temporary plastic shims and use construction epoxy for a solid bed.
- k) Protect the Drain Seat from damage & debris.
- l) Complete under floor connections from below or through access opening. Leak test.

4) Disassembling the WB RTDO

- a) Now that the Tub is in position, and the Floor Flange is positioned, for installation, you will need to unscrew the entire Tower Assembly from the Floor Flange.
- b) It is best to unscrew the Tube with the Control Knob in the "Up" or "Draining" position. Lift and turn the Control Knob a quarter turn.
- c) Unscrew the Lid maintaining the Control Knob in the "Up" position. Once unscrewed, carefully lift the Inner Tube assembly out of the tube, and store in a safe, clean place so that it does not get dirty, scratched or damaged.
- d) Unscrew the Outer Tube from the Floor Flange, and store in safely.
- e) Remove the Trim Escutcheon.
- f) Ensure that debris does not get on to the Drain Seat or into the drain area generally.

Note: When assembling the Outer Tube back on to the Floor Flange, use Teflon Tape or Joint Compound to ensure a watertight fitting.



UPDATED
VERSION
OCT 2009

WATERBRIDGE REMOTE TUB DRAIN & OVERFLOW (WB RTDO)
Shown with Sonoma Cast Stone's "DoubleWave" soaking tub

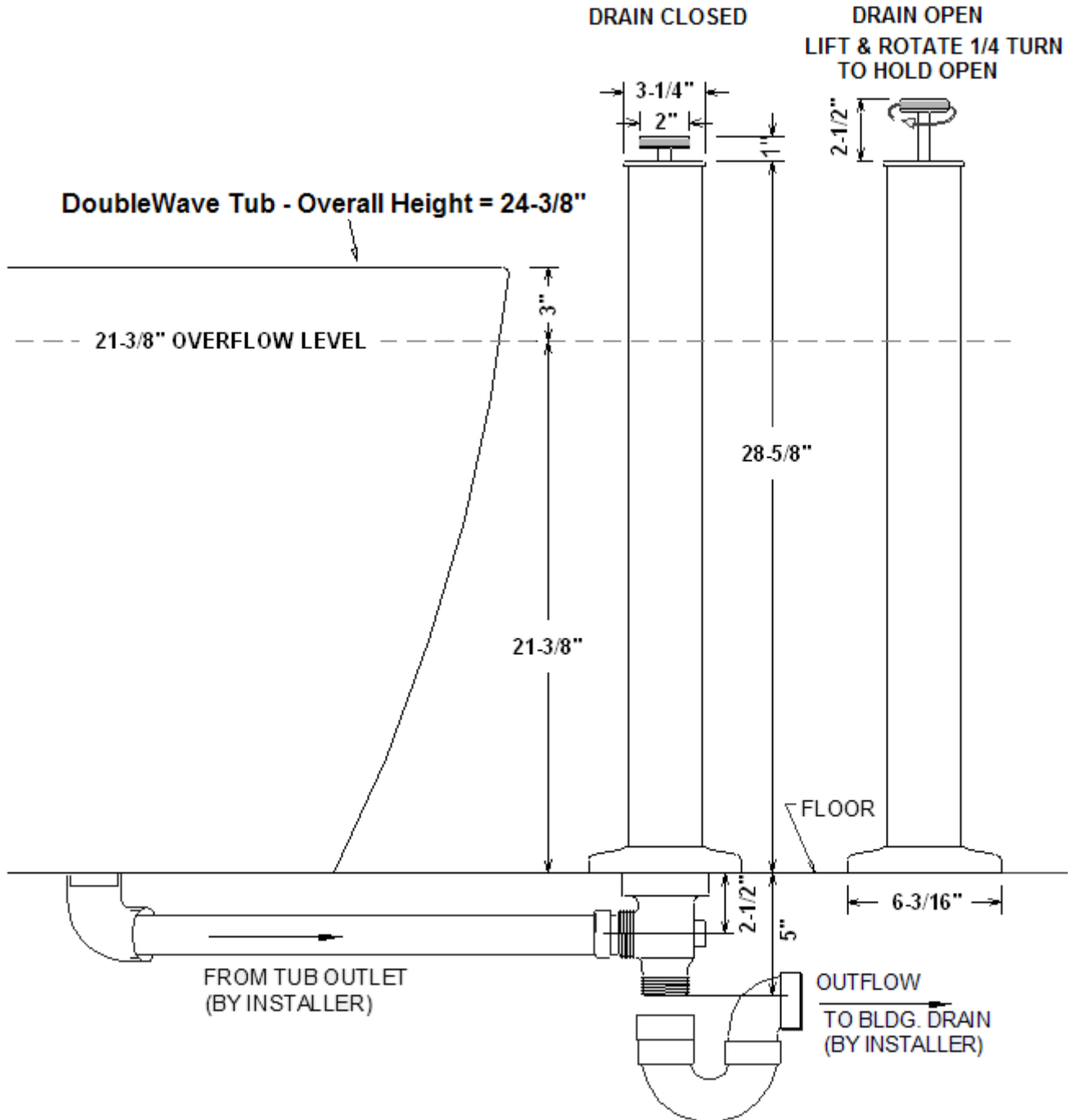



UPDATED
VERSION
OCT 2009

Control Knob in
Down position –
Drain is Closed –
Tub fills and
Overflow Tower
fills until selected
Overflow level –
then water flows
into inner tube and
down drain



Control Knob in Up
position –
Drain is Open –
Tub Drains



Adjustable
Overflow Height –
Calibrated in
inches from 19-23
or 25 ½ inches
from Finished
Floor.

Rubber sleeve
adjusted to desired
overflow height
(depending on tub
spec)

Control Knob in
Down position –
Drain is Closed –
Tub fills and
Overflow Tower
fills

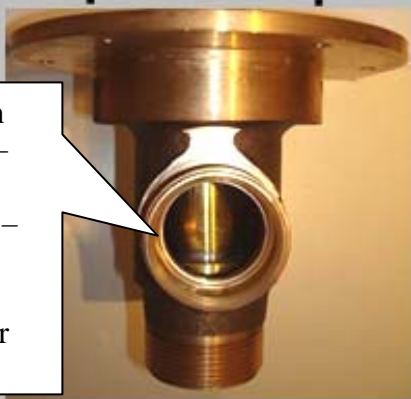

Control Knob in
Up position –
Drain is Open –
Tub Drains



UPDATED
VERSION
OCT 2009

5) **Assembling the WB RTDO – Outer Tube**

- a) Once the Floor Flange is installed and connected and water tested, re-install the Outer Tube.
- b) Make sure the Drain Seat is clean and smooth.
- c) Apply Teflon Tape or Joint Compound to the outside threads at the bottom of the Outer Tube.
- d) Carefully, thread the Outer Tube into the Floor Flange. Tighten with no-mar strap wrench.
- e) Slip the Escutcheon over the top end of the Tower Body.
- f) Slide the Trim Escutcheon down to the floor.
- g) Parts must be clean.
- h) Prior to inserting the Inner Tube assembly, select the Overflow Height for the Tub you are using.

6) **Selecting the Overflow Height**

Note: This Overflow Tower Drain is designed to work with two Soaking Tubs manufactured by Sonoma Cast Stone Corp. It may also be used for other manufacturers' tubs. Depending on the height of the tub determines the overflow height needed. This Overflow Tower Drain can be set for different heights.

The Japanese style "Ofuro" Soaking Tub by Sonoma Cast Stone (Ht = 28-1/2") uses the top of the tube as the Overflow level (approx. 25-1/2"). The rubber sleeve (included) should be adjusted to cover all of the holes in the Inner Tube)

The "DoubleWave" Soaking Tub by Sonoma Cast Stone (Ht = 24-3/8"). The rubber sleeve (included) should be adjusted to the "hatch mark from the top Inner Tube (approx. 21-3/8").

For Other Manufacturers' tubs, the Overflow setting depends on the tub height (Overflow Height usually equals 3" below the rim of the tub). Measure down from the top of the Inner Tube (+/- 25-1/2") to the tub's Overflow Height. Adjust rubber sleeve to that height.

This height can also be determined using Inner Tube assembly. Prior to threading the Outer Tube back in to the Floor Flange, place the Inner Tube assembly into the Floor Flange so that it seats on to the Drain Seat. Measure the Overflow Height needed from the top of the floor flange (add 1/4" for the Flange thickness). Mark the Inner Tube and adjust the sleeve to that position.

7) **Assembling the WB RTDO – Inner Tube**

- a) Now that the Outer Tube is in place and the Overflow Height has been selected for the tub, re-insert the Inner Tube into the Outer Tube.
- b) Guide the Inner Tube carefully through the Floor Flange and into the Drain.
- c) Prior to threading the Lid, it is suggested to place the Control Knob in the "Up" or Draining position.
- d) Screw the Lid into the Outer Tube.



UPDATED
VERSION
OCT 2009

8) Check the Drain function

- a) Move the Control Knob up and down - it should move smoothly. In the Up (Drain) position, turn the knob slightly until it rests on its own to hold the drain open.
- b) To close (Fill position), turn the Control Knob slightly until it can move downward. This will seat the O-Ring on the Drain Seat allowing the tub to fill.
- c) Fill the tub to normal bathing level. If stopper seal leaks, check for debris at the seal.
- d) Fill the required overflow level - normally at least 3" below the rim of the tub.
- e) If the Overflow level is too low, unscrew the Lid and adjust the rubber sleeve on the Inner Tube to a higher position.
- f) If the overflow level is too high, remove the Lid, and adjust the rubber sleeve to a lower position.
- g) Adjust in small increments for best results.

9) Maintenance

- a) Do not use abrasive or caustic cleaners.
- b) The Lid & Inner Tube assembly may be removed and a wet-dry shop vac used to clean hair and debris from the Stopper Seat.
- c) The Stopper O-Ring at the bottom of the inner tube may be replaced if necessary due to wear or damage.
- d) The rubber sleeve on the Inner Tube may be replaced if needed.