



INSTALLATION DETAILS

Strap Pressure Balance Shower ST-PB

March 2015



Specifications	
Minimum operating pressure:	20PSI
Maximum operating pressure:	125PSI
Maximum hot water temp. :	190 ° F
Hot & Cold water inlets:	1/2" NPT Male
Water Outlets:	1/2" NPT Male
Flow Capacity:	5GPM/60 PSI

Before you Start

1. FLUSH lines of debris prior to starting. Debris may clog cartridge.
2. The mud guard represents a typical hole size required to access the integral service stops and the removable cartridge. The rough valve comes PRE-ASSEMBLED and FACTORY READY TO INSTALL.
3. Be alert that the valve body is not installed upside down. See markings on BACK of valve.
4. The screwdriver service stops should always be in the full-open position with the valve in use. They are not to be used to restrict flow of either hot or cold inlets. THE HOT AND COLD WATER MUST BE FULLY OPERATIONAL AT THE VALVE INLETS OR THE UNIT WILL NOT FUNCTION PROPERLY DURING TESTING OR EVEN FLUSHING.
5. When soldering the valve body, it is NOT necessary to remove the cartridge assembly.
6. The unused port must be capped by plumber during installation.
7. Make sure to flush or raise grouting on a tiled wall surface to prevent seepage behind plate.

Rough-in of Valve

1. Rough valve body into wall, connecting piping to 1/2" Female copper sockets or 1/2" Male I.P. nipples.
NOTE "UP AND DOWN" MARKINGS ON BACK OF VALVE.
2. The depth of rough-in should account for thickness of wall materials to be used, combining thickness of wall board and finished wall materials. It is CRITICAL TO PLACE MUD GUARD FLUSH WITH FINISHED WALL. See FIG 1
3. Anchor installation to bracing between studs. (Ears on the valve body can be used by removing the plastic guard OR by anchoring the connection piping.)
4. Valve should be pressurized and tested for leaks at the connections. DO NOT close wall until valve is tested.
5. Mud guard should be left attached to the valve until the finished wall material is installed.
6. Use only propane or butane gas when soldering. Do not use oxygen / acetylene as extreme heat may damage internal components. Do not solder within 4 inches of valve port. Open stop valves when soldering inlets.

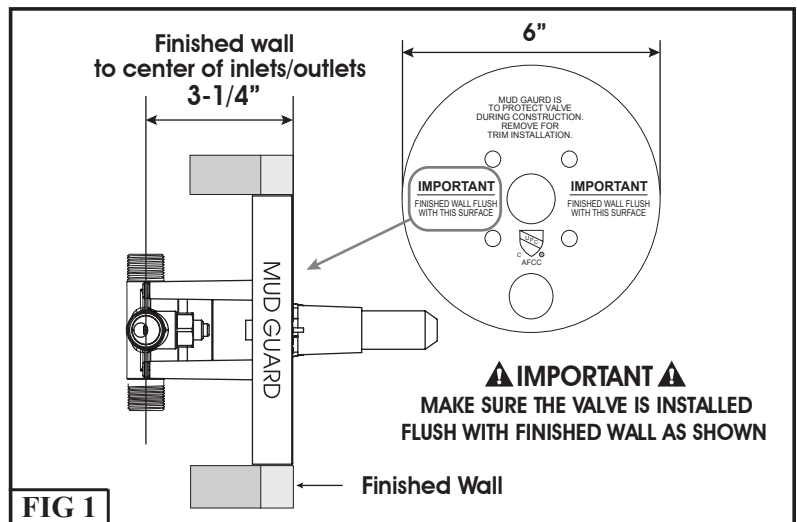

Setting Hot Stop Limit ⚠

IT IS THE RESPONSIBILITY OF THE INSTALLER TO SET THE MAXIMUM OUTPUT TEMPERATURE OF THE VALVE AS SPECIFIED BY THE AUTHORITY HAVING JURISDICTION IN ACCORDANCE WITH ASSE/ANSI 1016-2005 4.2.2 REQUIREMENTS.

1. To properly set the limit ring in accordance with local code requirements, you must use a thermometer or calibrated sensing device to accurately measure the outlet water temperature.
2. Turn off the water using both screw driver service stops.
3. Expose the top of the cartridge by removing the top hex cap from the valve body. FIG. 2
4. Remove the temperature ring by placing the blade of a knife into the groove and prying it off. FIG. 3. It is not necessary to remove the inner hex nut.
5. Locate the stop tab on the bottom of the ring. The further it is re-oriented in a counter-clock wise direction, the shorter the travel allowed (and thus, the lower the temperature output possible). It is suggested to allow approximately 8 splines of movement. However, local codes vary and water supply temperatures vary as well.
6. IMPORTANT!! BEFORE RE-ORIENTING THE RING, BE SURE THE STEM IS IN THE FULL OFF POSITION.
7. Re-install top hex cap using a wrench. Open both service stops and confirm the maximum hot water temperature.

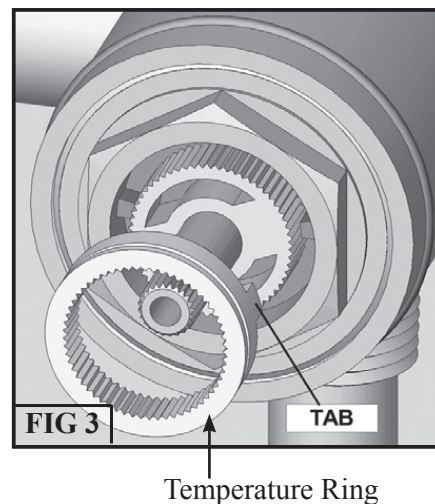
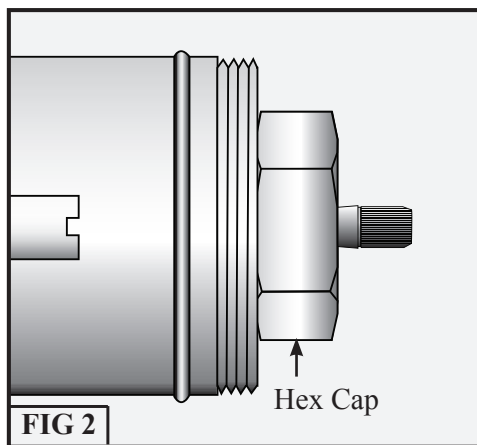

Plate and Handle Installation

Step 1: Cut Stem to so it is protruding 1-1/2" past the Trim Plate when flush against finished wall See **FIG 3**

Step 2: Mark the All-thread at 5/8" from the Trim Plate when flush against Finished Wall remove then cut the excess All-thread. Re-install the Stem and All-thread. See **FIG 3**

Step 3: Install the Flange using the 2 Plastic Washers and the Locking Nut to secure the Flange and Trim Plate to the wall. See **FIG 4**

Note: Make sure the o-ring on the flange is in-place to create a good seal.

Step 4: Install the Strap assembly onto the Stem Extension and thread the Top Screw into the Stem. See **FIG 5**.

Note: The Strap assembly should rest on the washers installed in Step 3.

Step 5: Install the lever by inserting the lever into the strap and locking the lever into place with the back cap. See **FIG 5**.

Note: The Lever Assemblies have 2 Pins that line up with Notches in the Strap to prevent the Lever from rotating.

Step 6: Test system to complete the installation.

